



## Universal Relay Driver

### Features

- ❑ 10V to 450V Input Voltage Range
- ❑ Energy Saving Hold Current Mode
- ❑ Adjustable Microcontroller Supply
- ❑ Low Supply Current <1mA
- ❑ Constant Current Coil Drive
- ❑ Programmable Pull-in Current, Pull-in Time, and Hold Current
- ❑ Efficient PWM Operation Using the Relay Coils' Inductance

### Applications

- ❑ Industrial Controls
- ❑ Relay Timers
- ❑ White Goods
- ❑ Solenoid Drivers
- ❑ Home Automation

### General Description

The Supertex HV9901 is a BiCMOS/DMOS universal relay driver that employs PWM switching techniques. It is designed for efficient and energy-saving operation of a low voltage relay with supply voltages ranging from 10 to 450V DC through utilization of the relay coils' inductance.

The circuit is capable of operating over a wide input voltage range without requiring a change of any external components. For example, this will enable users to use 5V coil relays for DC voltages 10 - 450V or AC voltages up to 240V.

The HV9901 has an internal high-voltage regulator to power internal PWM circuitry. Additionally it includes an adjustable auxiliary regulator with a 1mA capability that can be used to supply low power microcontrollers.

The pull-in current, pull-in time and hold current are all programmable using only two resistors and a capacitor. The PWM switching frequency can be either

- Synchronized to an external clock, or
- Synchronized to other HV9901s, where the synchronized frequency is the highest free-running frequency

The enable (ENI) logic input is used to turn the relay on/off. Enable polarity may be selected via the POL input. Audible noise is prevented using fixed switching frequencies above 20kHz.

**WARNING!!! Galvanic isolation is not provided. Dangerous voltages are present when connected to the AC line. It is the responsibility of the designer to ensure adequate safeguards are in place to protect the end user from electrical shock.**

### Typical Application Circuit

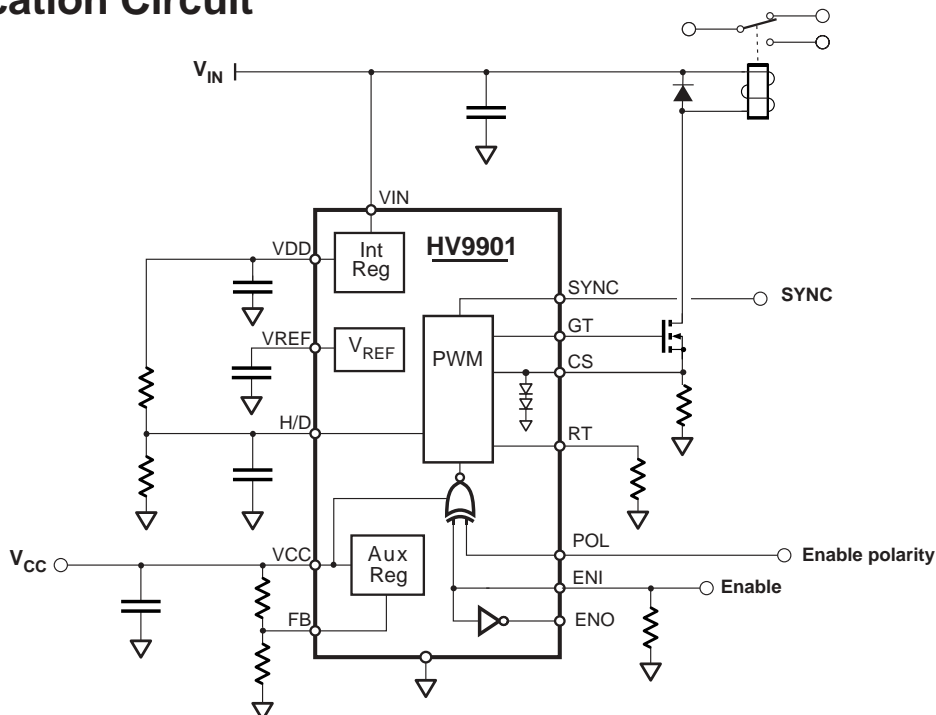

## Ordering Information

Package Options	
16 Lead Plastic DIP	16 Lead Plastic SO
HV9901P	HV9901NG

## Absolute Maximum Ratings

Input voltage, $V_{IN}^2$	-0.5 to +470V
Input voltage to any other pin <sup>2</sup>	-0.3V to $V_{DD}+0.3V$
Continuous total power dissipation for DIP	1000 mW <sup>1</sup>
Continuous total power dissipation for SO	750 mW <sup>1</sup>
Operating Temperature Range	-40 to +85°C

Note 1: For operation above 25°C ambient derate linearly at 7.5 mW/°C.

Note 2: All voltages are referenced to COM.

## Pin Configuration

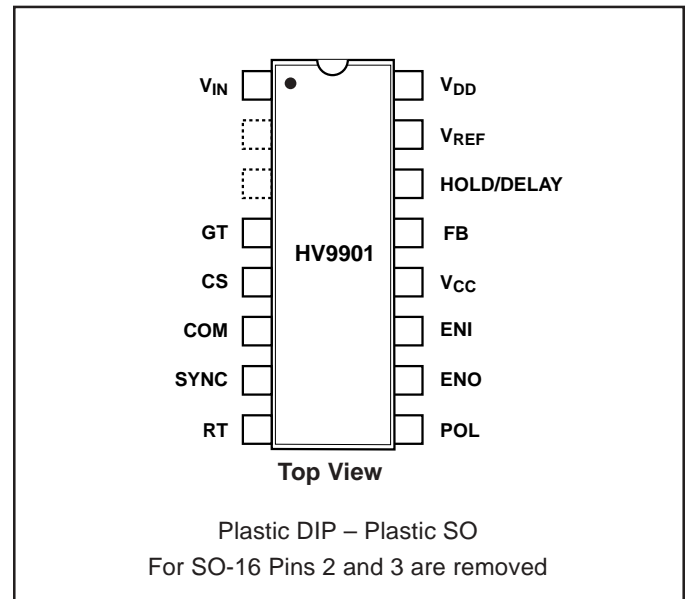

## Electrical Characteristics

( $T_A = 25^\circ\text{C}$ , unless otherwise specified)

Symbol	Parameters	Min	Typ	Max	Unit	Conditions
--------	------------	-----	-----	-----	------	------------

### High Voltage Regulator

$V_{IN}$	Input Voltage	10.0		450	V	$I_{CC} = 0$ to 1mA load
$I_{IN}$	Supply Current			2.0	mA	no load at $V_{DD}$ , load at $I_{CC} = 1\text{mA}$ , $C_{GT} = 500\text{pF}$ , $f_{OSC} = 25\text{KHz}$
$V_{DD}$	Regulator Output Voltage	8.5	9.0	9.5	V	no load at $V_{DD}$ , $C_{GT} = 500\text{pF}$ , $f_{OSC} = 25\text{KHz}$
$UV_{ON}$	$V_{DD}$ Under Voltage Lockout, ON	7.8	8.2	8.5	V	
$UV_{HYS}$	$V_{DD}$ Under Voltage Lockout, Hysteresis		0.5		V	

### Adjustable Regulator

$V_{CC}$	Regulator Output Voltage Range	2.0		5.5	V	$I_{CC} = 1.0\text{mA}$ load
$I_{CC}$	Regulator Output Current	0		1.0	mA	no load at $V_{DD}$ , See Note
$V_{FB}$	Feed Back Voltage	0	$V_{REF}$	$V_{DD} - 1.0V$	V	
$I_{FB}$	Input Bias Current		25	100	nA	$V_{FB} = V_{REF}$

Note: Maximum allowable load current limited by power dissipation and operating ambient temperature.

### Reference ( $T_A = 25^\circ\text{C}$ unless otherwise noted)

$V_{REF}$	Bandgap Reference Voltage	1.20	1.25	1.30	V	$T_A = -40^\circ\text{C}$ to $+85^\circ\text{C}$
$V_{REF}$	Load Regulation			7.0	mV	$0\text{mA} < I_{REF} < 0.3\text{mA}$
$V_{REF}$	Line Regulation		10.0	15.0	mV	$8.5V < V_{DD} < 9.5V$
$I_{REF(SHORT)}$	Short Circuit Current			1.0	mA	
$I_{REF(SINK)}$	Reference Voltage Sink Current			20	$\mu\text{A}$	

## Electrical Characteristics

( $T_A = 25^\circ\text{C}$ , unless otherwise specified)

Symbol	Parameters	Min	Typ	Max	Unit	Conditions
--------	------------	-----	-----	-----	------	------------

### Oscillator

$f_{\text{OSC}}$	PWM Oscillator Frequency	20	25	35	kHz	$R_T = 1.00\text{M}\Omega$
		80	100	140	kHz	$R_T = 226\text{K}\Omega$
	Temperature Coefficient		170		ppm/ $^\circ\text{C}$	$T_A = -40^\circ\text{C}$ to $+85^\circ\text{C}$
$f_{\text{SYNC}}$	Oscillator Sync Frequency			150	kHz	
SYNC	Sync. Input/Output Sourcing Current	20		55	$\mu\text{A}$	
SYNC	Sync. Input/Output Sinking Current	1.0			mA	$V_{\text{SYNC}} = 0.1\text{V}$
$V_{\text{SYNC}}$	Sync Input Logic Low Voltage			1.0	V	

### PWM

$D_{\text{MAX}}$	Maximum Duty Cycle	96.5		99.5	%	$R_T = 1.00\text{M}\Omega$
$D_{\text{MAX}}$	Maximum Duty Cycle	86.5		97.5	%	$R_T = 225\text{K}\Omega$
$t_{\text{BLNK}}$	Blanking Time	150	215	280	ns	

### MOSFET Driver Output

$V_{\text{GTH}}$	Gate Drive Output High	$V_{\text{DD}} - 0.3$			V	$I_{\text{OUT}} = 10\text{ mA}$
$V_{\text{GTL}}$	Gate Drive Output Low			0.3	V	$I_{\text{OUT}} = -10\text{ mA}$
$t_{\text{R}}$	Rise Time		30	50	nsec	$C_{\text{GT}} = 500\text{pF}$
$t_{\text{F}}$	Fall Time		30	50	nsec	$C_{\text{GT}} = 500\text{pF}$

### Current Sensing

$V_{\text{CS(HL)}}$	Current Sense Voltage, high limit	0.775	0.833	0.891	V	
$t_{\text{DELAY(HL)}}$	Current limit delay to GT high limit		200	250	ns	50mV overdrive
$I_{\text{CS}}$	Input Bias Current		25	1000	nA	POL=LOW, ENI=LOW
$V_{\text{OS}}$	Low limit comparator input offset voltage			$\pm 60$	mV	
$t_{\text{DELAY(LL)}}$	Current limit delay to GT, low limit		200	250	ns	50mV overdrive
$V_{\text{HOLD/DEL}}$	Hold/Delay output voltage	$V_{\text{DD}} - 0.4$			V	$I_{\text{HOLD/DEL}}$ (Sourcing)-100 $\mu\text{A}$ , POL=LOW, ENI=HIGH
$I_{\text{HOLD/DEL}}$	Hold Delay Input Bias Current		25	500	nA	POL=LOW, ENI=LOW

## Electrical Characteristics, continued

( $T_A = 25^\circ\text{C}$ , unless otherwise specified)

Symbol	Parameters	Min	Typ	Max	Unit	Conditions
--------	------------	-----	-----	-----	------	------------

### Enable Logic

$t_{\text{ENI}}$	Shutdown Delay		50	100	nsec	$2\text{V} < V_{\text{CC}} < 5.5\text{V}$
$V_{\text{ENI}}$	Enable Input Voltage - High	$0.7V_{\text{CC}}$		$V_{\text{CC}}$	V	$2\text{V} < V_{\text{CC}} < 5.5\text{V}$
$V_{\text{ENI}}$	Enable Input Voltage - Low	0		$0.3V_{\text{CC}}$	V	$2\text{V} < V_{\text{CC}} < 5.5\text{V}$
$I_{\text{ENI}}$	Enable Input Current - High		1.0	5.0	$\mu\text{A}$	$2\text{V} < V_{\text{CC}} < 5.5\text{V}$
$I_{\text{ENI}}$	Enable Input Current - Low	-5.0	-1.0		$\mu\text{A}$	$2\text{V} < V_{\text{CC}} < 5.5\text{V}$
$V_{\text{POL}}$	Polarity Voltage - High	$0.7V_{\text{CC}}$		$V_{\text{CC}}$	V	$2\text{V} < V_{\text{CC}} < 5.5\text{V}$
$V_{\text{POL}}$	Polarity Voltage - Low	0		$0.3V_{\text{CC}}$	V	$2\text{V} < V_{\text{CC}} < 5.5\text{V}$
$I_{\text{POL}}$	Polarity Current - High		1.0	5.0	$\mu\text{A}$	$2\text{V} < V_{\text{CC}} < 5.5\text{V}$
$I_{\text{POL}}$	Polarity Current - Low	-5.0	-1.0		$\mu\text{A}$	$2\text{V} < V_{\text{CC}} < 5.5\text{V}$
$V_{\text{ENO}}$	Enable Output Voltage - High	$0.9V_{\text{CC}}$		$V_{\text{CC}}$	V	$2\text{V} < V_{\text{CC}} < 5.5\text{V}$
$V_{\text{ENO}}$	Enable Output Voltage - Low	0		$0.1V_{\text{CC}}$	V	$2\text{V} < V_{\text{CC}} < 5.5\text{V}$

### Enable Logic Truth Table

POL	ENI	ENO	Gate Drive Output
LOW	LOW	HIGH	$V_{\text{GT}} = \text{Oscillating Output}$ , Duty Cycle depends on Inductive Load
LOW	HIGH	LOW	$V_{\text{GT}} = \text{LOW}$ , SYNC = HIGH, Oscillator shut down.
HIGH	HIGH	LOW	$V_{\text{GT}} = \text{Oscillating Output}$ , Duty Cycle depends on Inductive Load
HIGH	LOW	HIGH	$V_{\text{GT}} = \text{LOW}$ , SYNC = HIGH, Oscillator shut down.

# Applications Information

$$I_{PULL-IN} = \frac{V_{CS(HL)}}{R_{SENSE}} \quad V_{CS(HI)} = 833\text{mV nom}$$

$$V_{CS(LL)} = \frac{V_{DD}}{1 + \frac{R_{HDa}}{R_{HDb}}} \quad V_{DD} = 9.0\text{V nom}$$

$$I_{HOLD} = \frac{V_{CS(LL)}}{R_{SENSE}}$$

$$t_{PULL-IN} = -(R_{HDa} \parallel R_{HDb}) C_{HD} \ln \left( 1 - \frac{V_{CS(HL)} - V_{DD}}{V_{CS(LL)} - V_{DD}} \right)$$

$$f_{PWM} \approx 3.23\text{kHz} + \frac{21.8\text{GHz} \cdot \Omega}{R_{OSC}} \quad (\text{valid for } f_{pwm} > 23\text{kHz})$$

$$V_{CC} = 1.25\text{V} \left( 1 + \frac{R_{FBa}}{R_{FBb}} \right)$$

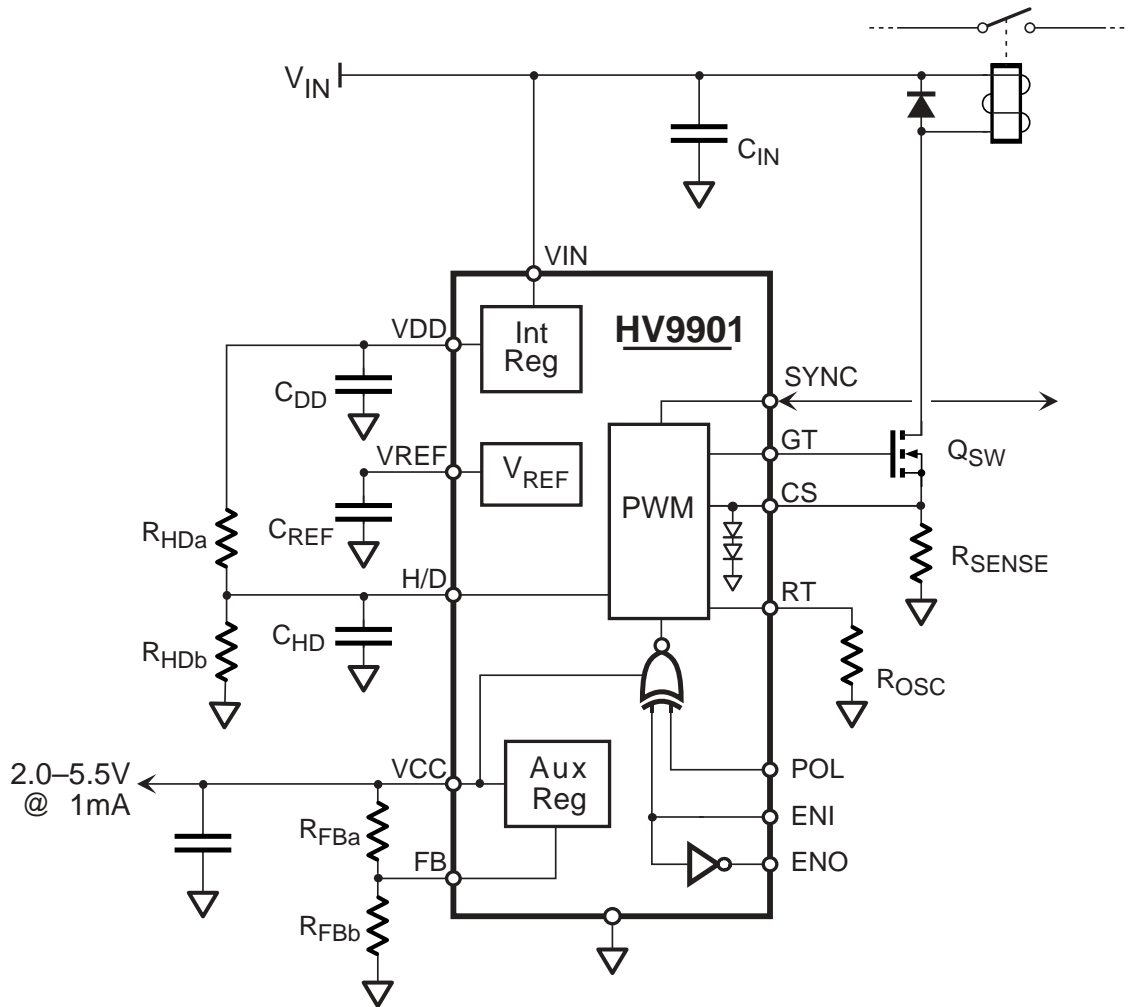
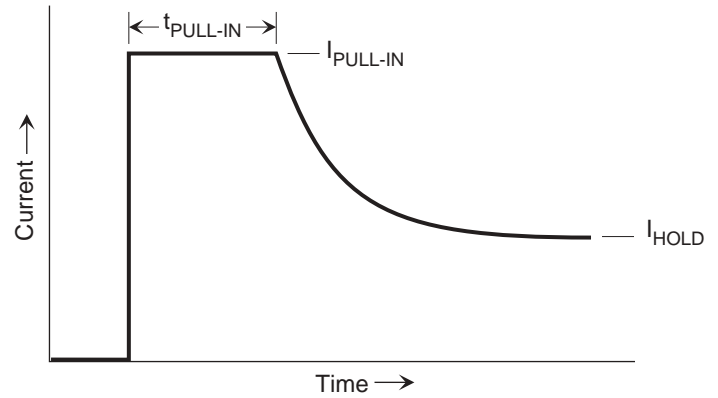

# Functional Block Diagram and Typical Application

- Notes: 1. This diode and bridge rectifier required only for AC operation.  
 2. For non-isolated AC operation the entire circuit must be floating.  
 3. All comparators have open drain outputs.

